



2024
Line construction Equipment

Our Vision:

Excel to be a global market leader in our field, setting standards in our industry by producing and trading a wide range of innovative tension stringing and other equipment in symbiotic relation with ZECK Germany.

Our Mission:

- Develop and manufacture products with unique features and of outstanding quality.
- Achieve maximum benefit for our clients.
- Develop excellency in products/service/and on time delivery.
- Fulfill our employees with pride about being part of Zeck TSE and the ZECK group of companies.
- Enhance the capabilities of our employees with opportunities to improve their functional knowledge and skills.
- Increase our competitiveness by continuously improving internal and external processes.



TENSION STRINGING
EQUIPMENT

Index

Our Company	4
Our Service	5
Sustainability	6
<i>Tower erection</i>	
Puller 50kN	7
Ginpoles	8
<i>Conductor Pulling</i>	
Pulling Ropes	10
Steel Reels	12
Heavy Duty Pulling Grips	14
Drum Stand for Overhead Stringing	15
Hydraulic Reel Winder	16
Reel Winder	17
Pulley Blocks for Helicopter Stringing - Nylatron Sheaves	18
Pulley Blocks for Helicopter Stringing - Aluminum Sheaves	19
Tandem Pulley Blocks (Helicopter)	20
Array Block	21
Hold-Down Block	22
Pulley Block Storage System	22
Joint Protectors	23
OPGW Counterweight	23
<i>Compression, Sagging, Spacer Installation</i>	
Hydraulic Compression Machines	24
Suspension Ladders	26
Anchoring Ladders	28
Working Platforms	30
Sagging Thermometer + Scope + Spacerkey	32
Line Cars	33
Line bicycles	40
<i>Railway Construction Equipment</i>	
Railway Construction Equipment	41
<i>Underground Utility Construction (Thailand only)</i>	
CBS	43
Föckersberger	44



Our company ZECK TSE International Ltd.

Established in 2011, Zeck TSE International Ltd. is a subsidiary of Germany's ZECK GmbH, one of the most trusted international specialists in Tension Stringing Equipment (TSE) for power transmission line construction. Rooted in a family-owned legacy spanning over a century, Zeck TSE inherits 58 years of ZECK GmbH's expertise in designing and manufacturing Tension Stringing Equipment.

Initially, the company focused on braided wire ropes in Thailand, but has continuously expanded its product range over the years. Today, Zeck TSE exports a wide range of products and manages sales and service for ZECK GmbH in Asia, the Middle East and large parts of Africa. Strategically located in the Eastern Economic Corridor in Chonburi near Bangkok and only 30 kms away from the international deep seaport Laem Chabang, the company's 16,000 m² factory employs 90 dedicated professionals.

Diversifying into Underground Utility Construction, Zeck TSE represents top European manufacturers in Thailand for the cable ploughing system "Spider Plough" (Foeckersperger) and fibre optic cable installation technologies (CBS), signaling its commitment to emerging markets.



Our mother company ZECK GmbH in Germany

Founded in 1918 post-World War I, ZECK GmbH evolved from an agricultural machinery focus to become a world leading developer and manufacturer of Tension Stringing Equipment. In October 2020, the company celebrated the production of its 10,000th machine, an 18-ton Puller-Tensioner WB 1800/18. With around 250 highly skilled employees, ZECK GmbH excels in technical innovation, user-friendliness, and after-sales service. The company is frequently awarded as one of the best medium-sized machine manufacturers in Germany and serves as a model for its Thai subsidiary, Zeck TSE International Ltd.

For the complete product range please refer to the catalogue of ZECK GmbH, Germany www.zeck-gmbh.com



Our Service

After Sales

For almost a century, ZECK has championed the cause of delivering extensive and dependable after-sales services. We are committed to offering our valued customers individual assistance that meets their specific needs whenever they need it.

Together with our mother company in Germany, ZECK GMBH, and our various other locations, we are able to send our most experienced technicians to assist you globally within 24 hours.

- Services:
- Spare Part Delivery
 - General Overhaul
 - Machine Transport
 - Commissioning
 - Customer Service
 - Safety Check
 - General Inspection



Technical Support

Do you need technical support or replacement parts? ZECK customers can call our technical support Monday to Friday from 07:00 am to 04:30 pm

To be able to process your case quickly, please have the exact machine data ready:

- Type (on the typeplate right corner below)
- Chassis No. (typeplate bottom right, second line)



Tel : +66 63 193 4471 E-Mail : rp@zeck.co.th

Rental Machines

If you only need a ZECK machine temporarily, we've got you covered: Our fleet of rental machines is ready when you are, offering quick solutions at budget-friendly rates.

Unlock the power of ZECK machines without the commitment of a big investment!

We are here for you, offering instant assistance.



Tel : +66 62 229 1645 E-Mail : info@zeck.co.th

Sustainability: A Holistic Commitment

Sustainable development is an important principle for all of us at ZECK TSE as we recognize the profound impact it has on our collective future. Our dedication to protecting the planet goes beyond technological advancement: It embraces a holistic approach that prioritizes people, ethics, and the environment, aligning with the UN development goals.

Sustainable Technologies: At ZECK TSE, we actively work towards reducing emissions, enhancing energy efficiency, and promoting renewable energy sources. Our machines are equipped with low-emission engines and automated controls, optimizing operations to minimize errors, lower pollutants, and increase energy efficiency. Continuous updates prioritize emission reduction, engine electrification, and components designed to prevent fluid leakage.

Environmentally Friendly Production: In our Chonburi factory, efficiency, safety, and quality are paramount throughout the production process. We lead the way in the Thai industrial production landscape by minimizing the use of environmentally harmful materials and ensuring proper waste disposal practices.

Socially Responsible, Supportive, and Safe Workplace: Our commitment to sustainability extends into the workplace, where we prioritize people and ethical practices. Guiding principles include upholding human rights, fostering a positive work environment, maintaining ethical conduct in business operations, and nurturing respectful relationships with stakeholders.

3 GOOD HEALTH
AND WELL-BEING



Critical vaccines and free health check-ups for all employees.

4 QUALITY
EDUCATION



Scholarships to empower individuals in advancing their skills, refining their roles, and contributing to the collective knowledge of the organization.

5 GENDER
EQUALITY



Equal rights to benefits and preventing any form of wage discrimination.

8 DECENT WORK AND
ECONOMIC GROWTH



Promoting equal opportunities in employment, fostering job growth, and supporting youth employment through training initiatives.

9 INDUSTRY, INNOVATION
AND INFRASTRUCTURE



Build infrastructure that is both safe and resilient, with a steadfast commitment to sustainability.

10 REDUCED
INEQUALITIES



Virtually no inequalities in our company.

12 RESPONSIBLE
CONSUMPTION
AND PRODUCTION



Locally sourced raw materials, Waste reduction and recycling of waste.

17 PARTNERSHIPS
FOR THE GOALS



Various MOUs to manage the exchange of best practices with business partners and the Royal Thai Vocational Education Commission to strengthen collaboration and support of vocational education initiatives.

Puller 50 kN

This machine is a compact, light and very powerful hydraulic double capstan winch for pulling of a single rope with up to 50 kN force. For heavy duty tower erection, cable pulling and other applications it is ideally suited. It comes with an integrated rope storage drum, hydraulic reelwinder and rope level wind. The capacity of the drum is 350 m of for instance 16 mm rope. For longer pulls a separate reelwinder can be attached to an optional available hydraulic power take-off.

Part No.	Description
PUL-01-05	Standard version on steel frame and lockable aluminum cover with gas spring suspended flaps
PUL-00-01	1-Axle chassis with rigid axle for up to 30 km/h (construction site operation, without official approval for road service)
PUL-00-02	Hydraulic crawler chassis

A basic version without rope storage drum, hydraulic reel winder and level wind is available upon request (product number PUL-05-02).



PULLER PERFORMANCE

max. pulling force:	50 kN
max. speed:	26 m/min
speed at max pulling force:	26 m/min 10 m/min
min. speed at continuous pulling force:	2 m/min.

BULL WHEELS

number of bull wheels:	2
diameter of bull wheels:	255 mm
groove diameter:	22 mm
max. rope diameter:	22 mm
drum capacity/max rope length (Ø20 mm)	22 mm

DIMENSION/WEIGHT (PUL-01-05)

length x width x height:	1600x1650x1165 mm
weight:	900 kg

ENGINE

- max. 16.5 kW (22.1 hp)
- Honda GX690 with electro start

DRIVE SYSTEM

- hydraulic drive system
- bull wheel with completely closed drive unit (motor+brake+gear box) for minimal maintenance and high efficiency
- automatically activated safety brake system

CONTROL SYSTEM

- control of rope in/out via hand lever
- control instrument for the pulling force

GENERAL FEATURES

- steel frame with anchoring eyes

Ginpoles

Ginpoles are used for the erection of transmission line or telecom towers. In combination with lifting winches they function similar to crane arms. Once the tower has been erected up to a certain height, the Ginpole is lifted and anchored within the tower structure for further erection until the complete tower is mounted.

We fabricate Ginpoles made of high tensile aluminium with safe lifting loads from 10 kN up to 50 kN (pos.1, vertical). The standard lengths of our Ginpoles range between 8 and 30 meters. Standard wise we produce Ginpoles with the superior **internal rope guidance system**, which has integrated pulleys for the guidance of the rope. Upon request we also produce Ginpoles with **external rope guidance system**. We also produce longer Ginpoles upon request.

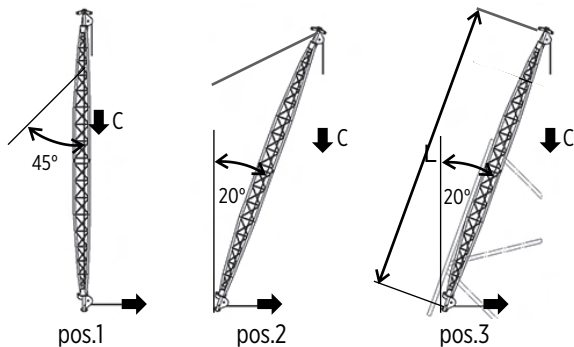

Lifting load is indicated in 3 positions: pos.1 vertical, pos. 2 with 20 degree inclination installed in the tower center, pos. 3 with 20 degree attached to a towerleg.

Please note: operation of the Ginpole always requires some inclination.

Part No.	Total length (m)	C - safe working load (SWL) (kN)			Sections (m)	Weight* (Kg)
		P1 pos.1 (a = 0°)	P2 pos.2 (a = 20°)	P3 pos.3 (a = 20°)		
GPI-01-0600	6	10	6	2.4	3+3	60
GPI-01-0800	8	10	6	2.4	4+4	79
GPI-01-1000	10	10	6	2.4	4+2+4	92
GPI-01-1200	12	10	6	2.4	4+4+4	105
GPI-02-1200	12	25	15	6	4+4+4	270
GPI-02-1600	16	25	15	6	4+4+4+4	321
GPI-02-1800	18	25	15	6	4+4+2+4+4	332
GPI-02-2000	20	25	15	6	5+5+5+5	369
GPI-03-1200	12	35	21	8	4+4+4	281
GPI-03-1600	16	35	21	8	4+4+4+4	329
GPI-03-2000	20	35	21	8	5+5+5+5	381
GPI-03-2500	25	35	21	8	5+5+5+5+5	438
GPI-05-1600	16	50	30	12	4+4+4+4	424
GPI-05-2000	20	50	30	12	5+5+5+5	488
GPI-05-2400	24	50	30	12	5+5+4+5+5	564
GPI-05-2500	25	50	30	12	5+5+5+5+5	569
GPI-05-3000	30	50	28	10	5+5+5+5+5+5	650

max. lifting rope dia. For GPI - 01/02 : 11 mm

max. lifting rope dia. For GPI - 03/05 : 14 mm

* The weight indication includes Groundplate as well as Ginpole Heads and Ginpole Feet with integrated snatch blocks (for superior internal rope guidance)

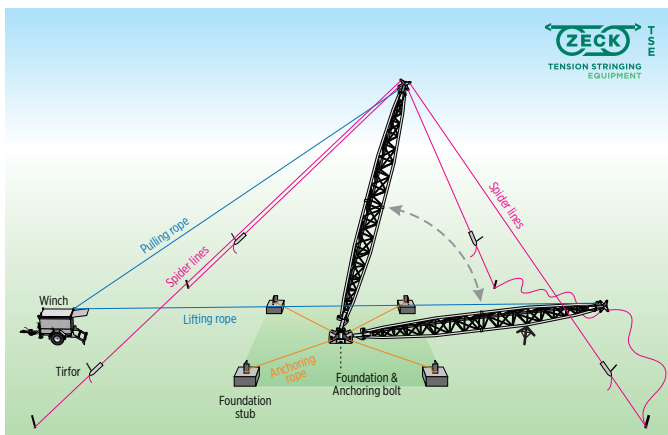

1. Assembly and Positioning of the Ginpole.

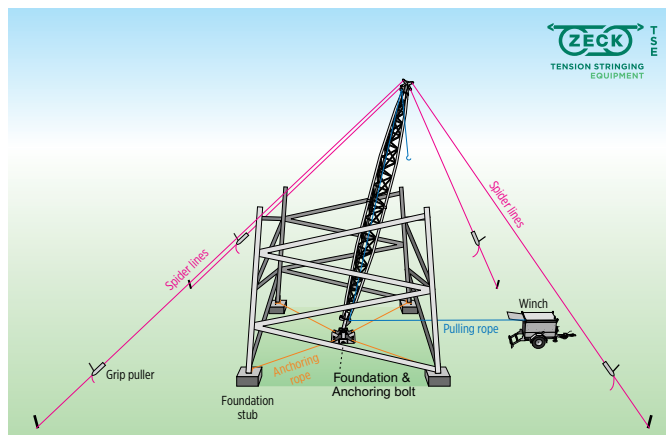

2. Using the Ginpole on the ground.

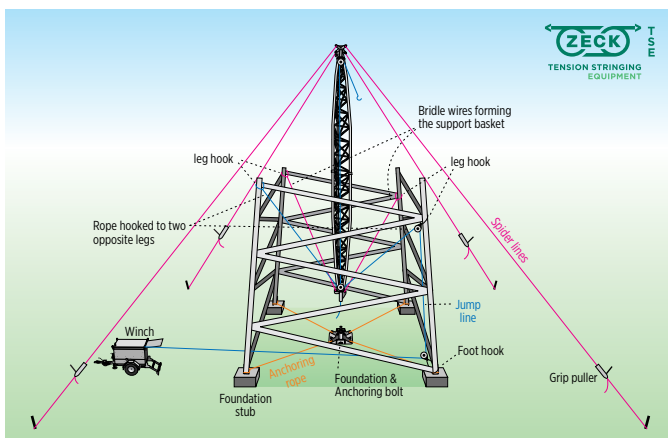

3. Lifting the Ginpole.

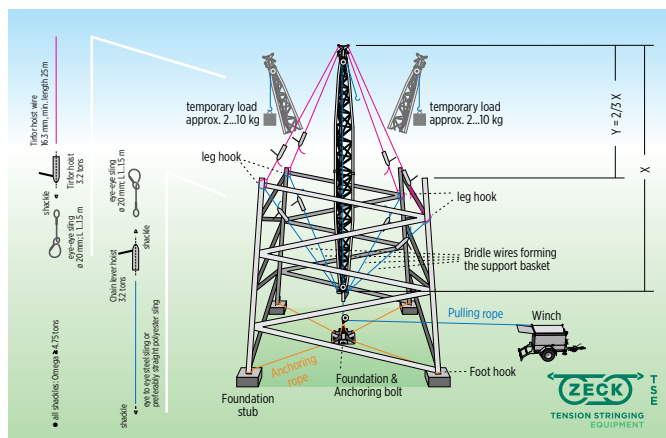

4. Using the Ginpole as a centrally placed floating Ginpole.



Pulling Ropes (Braided Steel)

“Performance” Series

Our braided steel wire ropes are torsion free because they are made of equal numbers of left and right winding wire strands. This makes them the perfect choice for conductor stringing with double capstan pullers.

These ropes are made of superior quality strands. The properties of our wire rope combine long endurance with high tensile strength. The strands are individually lubricated and manufactured in strict compliance with European standards.



SWR-XX-XX with optional marking tape

“Ultimate” Series

Our unique heavy duty HD ropes are now classified with a name that better reflects their exceptional properties: *Ultimate Ropes*.

The strands of these ropes are compacted, resulting in significantly less friction within and between strands. This shifts the focus of their properties to the two factors that really matter: strength and durability. The surface of the compacted strands is smoothed, which minimizes the likelihood of them climbing out of the pulley sheaves, especially under angled pulls. The higher breaking load of the Ultimate rope is achieved without an increased carbon content of the steel, thereby not sacrificing endurance in favor of breaking strength.



HDR-XX-XX with optional marking tape

Breaking Load (kN)	SWR-XX-XX “Performance” Ø (mm)	HDR-XX-XX “Ultimate” Ø (mm)
50	8	7
72	10	9
85	11	10
110	12	11
115	13	12
127	14	13
170	16	14
215	18	16
270	20	18
320	22	20
360	24	22
460	27	24
536	29	27
660	32	29
720	-	32
800	-	36

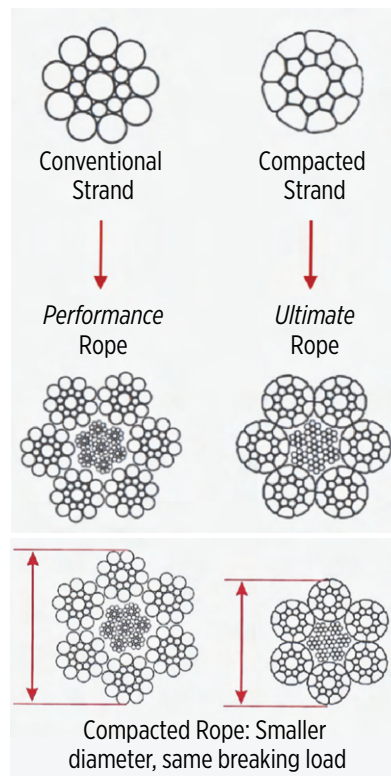

Pulling Ropes (Braided Steel)

Performance Ropes

Part No.	Ø Dia. (mm)	SWL (kN)	min BL (kN)	Weight (Kg/m)	Standard length (m)**	Max. length with reel dia.		
						1,100 mm	1,400 mm	1,900 mm
SWR-12-08	8	17	50	0.23	1600	3200	6400	12800
SWR-12-10*	10	24	72	0.33	1000	2000	4000	8000
SWR-12-11	11	28	85	0.39	800	1600	3200	6400
SWR-12-12	12	37	110	0.49	1400	1400	2800	5600
SWR-12-13*	13	38	115	0.56	1200	1200	2400	4800
SWR-12-14	14	42	127	0.68	1000	1000	2000	4000
SWR-12-16*	16	57	170	0.81	800	800	1600	3200
SWR-12-18*	18	72	215	1.10	1200	-	1200	2400
SWR-12-20*	20	90	270	1.35	1000	-	1000	2000
SWR-12-22*	22	107	320	1.52	900	-	900	1800
SWR-12-24*	24	120	360	1.80	800	-	800	1600
SWR-18-27	27	153	460	2.29	600	-	600	1200
SWR-18-29	29	179	536	2.59	500	-	500	1000
SWR-18-32	32	220	660	3.22	400	-	400	900

*produced on stock

**other lengths available upon request

Working loading is calculated according to European Standards (safety factor : 3.00)

Ultimate Ropes

Part No.	Ø Dia. (mm)	SWL (kN)	min BL (kN)	Weight (Kg/m)	Standard length (m)**	Max. length with reel dia.		
						1,100 mm	1,400 mm	1,900 mm
HDR-12-07	7	17	50	0.25	1600	3200	6400	12800
HDR-12-09	9	24	72	0.34	1000	2000	4000	8000
HDR-12-10	10	28	85	0.42	1000	2000	4000	8000
HDR-12-11	11	37	110	0.5	800	1600	3200	6400
HDR-12-12	12	38	115	0.64	1400	1400	2800	5600
HDR-12-13	13	42	127	0.7	1200	1200	2400	4800
HDR-12-14	14	57	170	0.8	1000	1000	2000	4000
HDR-12-16	16	72	215	1.01	800	800	1600	3200
HDR-12-18	18	90	270	1.19	1200	-	1200	2400
HDR-12-20	20	107	320	1.56	1000	-	1000	2000
HDR-12-22	22	120	360	1.74	900	-	900	1800
HDR-12-24	24	153	460	2.11	800	-	800	1600
HDR-18-27	27	179	536	2.61	600	-	600	1200
HDR-18-29	29	220	660	3.17	500	-	500	1000
HDR-18-32	32	240	720	3.79	400	-	400	800
HDR-18-36	36	267	800	4.21	300	-	300	700

Optional Equipment:

Part No.	Description
SWR-00-01	marking tape, indicating serial #, part #, length and manufacturing month/year

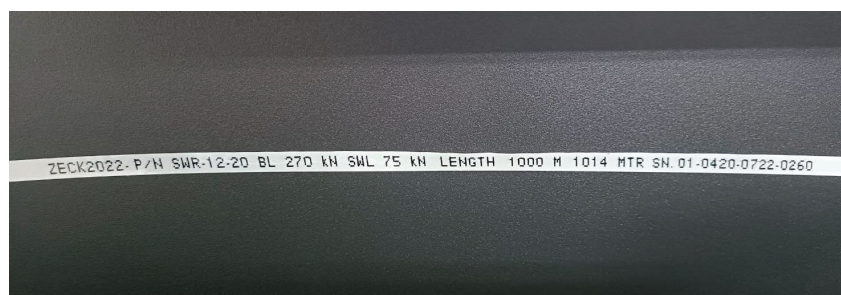

Steel Reels

Our steel reels are welded of steel tubes and finished with a high quality painting. Optionally we supply them hot-dip galvanized. For ZECK Pullers we optional supply them with welded or lasered crossplates. These reels are available in sizes of 520 up to 1,900 mm diameter. Detachable reels are supplied for re-conductoring works, when the wound up conductor needs to be scrapped. For extra long lengths of wire rope we supply galvanized steel drums with a capacity up to 13,000 KG.

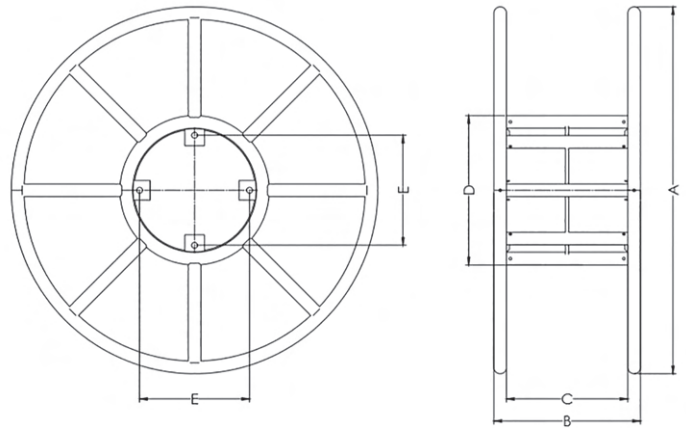

For special lengths of wire rope we supply steel drums of any customized size and strength.

non-detachable

Part No.	Dimensions in mm						Weight (Kg)
	A	B	C	D	E	F	
TSR-01-0520	520	420	334.6	264	160	50	24
TSR-01-1100	1100	560	460	570	420	50	68
TSR-01-1400	1400	560	460	570	420	50	82
TSR-01-1450	1450	560	460	570	420	50	85
TSR-01-1900	1900	560	460	570	420	50	108

hot-dip galvanized finishing

non-detachable

Part No.	Dimensions in mm							Weight (Kg)
	A	B	C	D	DT	E	F	
TSR-02-0520	520	420	334.6	264	-	160	50	21
TSR-02-1100	1100	560	460	570	-	420	50	64
TSR-02-1400	1400	560	460	570	-	420	50	80
TSR-02-1450	1450	560	460	570	-	420	50	83
TSR-02-1900	1900	560	460	570	-	50	50	106

painting finishing

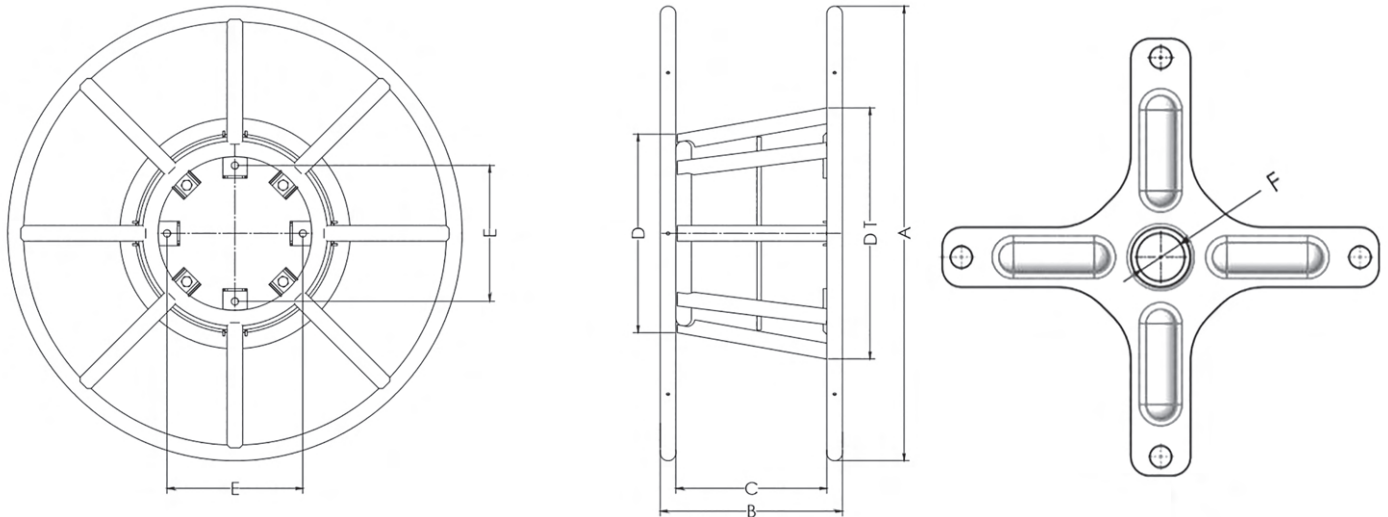

detachable

Part No.	Dimensions in mm							Weight (Kg)
	A	B	C	D	DT	E	F	
TSR-03-1100	1100	560	460	570	680	420	50	78
TSR-03-1400	1400	560	460	570	715	420	50	93
TSR-03-1900	1900	560	460	611	773	420	50	125

hot-dip galvanized finishing

Part No.	Dimensions in mm							Weight (Kg)
	A	B	C	D	DT	E	F	
TSR-04-1100	1100	560	460	570	680	420	50	76
TSR-04-1400	1400	560	460	570	715	420	50	90
TSR-04-1900	1900	560	460	611	773	420	50	123

painting finishing

Optional Equipment:

Part No.	Description	Thickness (mm)	Weight (Kg)
TSR-00-01	one pair of bolted crossplate, punched, electro galvanized plate for fitting the reel winder shaft of ZECK Pullers	6	5.20

Heavy Duty Pulling Grips

SINGLE with compressed eye or **DOUBLE** with two open ends

Because faulty pulling grips may cause serious accidents, for **ultimate safety** each grip is supplied with **individual serial number and electronic compression protocol**. Produced by ZECK TSE under strictest quality control.



Single Pulling Grips

Part No.	Rope dia.	SWL (kN)	Min BL (kN)	Min.grip length (mm)	Weight (kg)
SPG-01-0613	6 to 13	7	22	650	0.6
SPG-01-1219	12 to 19	27	85	825	0.7
SPG-01-1624	16 to 24	32	97	1,100	1.3
SPG-01-2532	25 to 32	48	145	1,400	2
SPG-01-3238	32 to 38	60	180	1,400	2.3
SPG-01-3848	38 to 48	78	235	1,400	3

safety factor: 3

Double Pulling Grips

Part No.	Rope dia.	SWL (kN)	Min BL (kN)	Min.grip length (mm)	Weight (kg)
DPG-01-0613	6 to 13	7	22	2 x 650	1.2
DPG-01-1219	12 to 19	13	40	2 x 825	1.4
DPG-01-1624	16 to 24	23	70	2 x 1,100	2.6
DPG-01-2532	25 to 32	32	95	2 x 1,400	4
DPG-01-3238	32 to 38	46	140	2 x 1,400	4.6
DPG-01-3848	38 to 48	50	150	2 x 1,400	6

safety factor: 3

Drum Stand for Overhead Stringing



Thanks to its easy transportability and capacity to install conductor drums without use of a crane this design is the most popular among transmissionline contractors worldwide. With the drumshaft being inserted conductor drums can be lifted by crane or manually rolled into the drumstand. Once in operating position the drumshaft will be rested on a mechanical holding device, so that the hydraulic jacks are freed from any constant load. The drumstand DST is equipped with two disk brakes for stationery purpose. For most efficient operation we highly recommend the use of hydraulic drum-drive motors.

Part No.	Model	Min. drum dia. (mm)	Max. drum dia. (mm)	Max. drum weight (Kg)	Max. drum width (mm)	Weight (Kg)
DST-01-070	TB IT 7	1600	2800	7000	1500	340
DST-01-100	TB IT 10	2000	3200	10000	2040	463

center shaft bore: min. 95 mm, max. 115 mm

Optional Equipment

Part No.	Description	Dimensions LxWxH (mm)	Weight (Kg)
DST-00-001	hydraulic hose set 15 m for TB/IT 7	-	26.70
DST-00-002	hydraulic drum drive: max. drive 2900 Nm	-	97
DST-00-003	transport box - TB IT 7	2250x920x750	65
	transport box - TB IT 10	2500x960x880	75
DST-00-004	adapter for steel drum	-	4.5*
DST-00-005	Bundle of drive unit and hose (DST-00-001 + DST-00-002)	-	-

special designs on request

* weight per piece

Hydraulic Reel Winder

The hydraulic reel winder, compatible with standard steel reels, is powered by either a ZECK machine or a ZECK hydraulic power unit. It features manually operated hydraulic cylinders equipped with a plug-in axle, facilitating swift and effortless loading and unloading of reels.

- Hot-dip galvanized, robust steel frame with anchoring eye bolts and forklift fixtures
- Disk brake system for the controlled tensioning of the rope without hydraulic support
- Automatic rope guiding device
- Special designs on request

Part No.	Max torque drive (NM)	Diameter disk brake (mm)	Max reel weight (Kg)	Reel Diameter (mm)	Reel Diameter (Ømm)	Dimensions LxWxH (mm)	Weight (Kg)
HTB E	1100	350	1700	IT: 1100-1400 ZECK: 1100-1380	IT: 45 ZECK: 35-40	1500 x1500x1500	460



Optional Equipment

Part Number	Description
DST-00-001	15 m hose kit with quick-action coupling (other lengths available)
HPU-01-0240	Hydraulic power unit

Reel Winder

This is a simple reelwinder without drive unit to feed out pulling ropes. It has a robust steel frame with anchoring eye bolts, hot-dip galvanized. It allows quick and easy loading and unloading of reels, dismountable for reduced transport dimensions.



Part No.	Max. reel dia. (mm)	Max. reel weight (Kg)	Shaft dia. (mm)	Dimensions LxWxH (mm)	Weight (Kg)
REW-01-1400	1,400	1,500	45	2600x1300x1100	85

Optional Equipment

Part No.	Description	Dimensions LxWxH (mm)	Weight (Kg)
REW-00-01	disk brake	-	15

Pulley Blocks for Helicopter Stringing – Nylatron Sheaves

- Sheaves casted of very strong and durable solid Nylatron
- For single conductor, 2-, 3-, or 4-bundle
- Hinge mechanism, ball bearing mounted, for automatic insertion of the rope
- Galvanized steel frame with clevis attachment rotatable by 90°
- Maintenance-free ball bearings with high safe working load

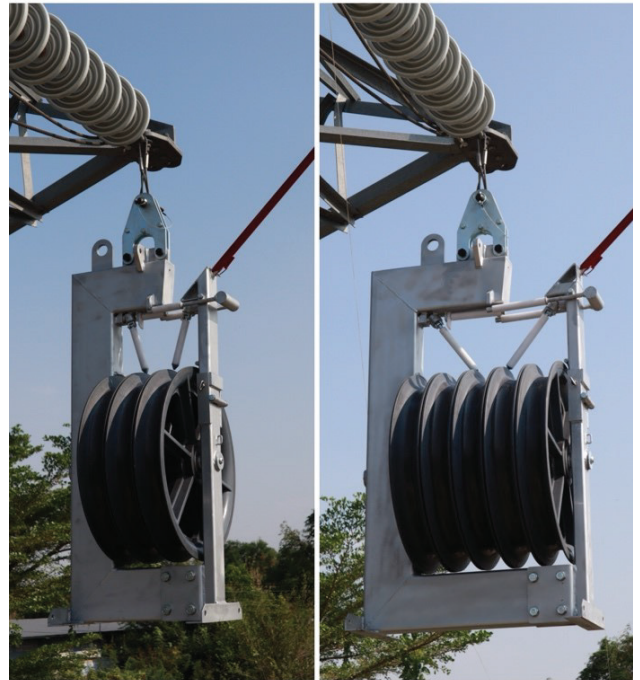

Optional

- Alternative distance between sheaves (H)
- Fixed clevis
- Grounding device with conductor rollers
- Special designs and breaking load on request

Part No.	Number of wheels	A (mm)	B (mm)	C (mm)	D (mm)	E (mm)	F (mm)	H (mm)	I (mm)	Breaking load (kN)	Working load (kN)	Weight (kg)
HPB-01-0650-NY	1	750	650	95	17	20.5	1258	-	-	141	47	69
HPB-01-0850-NY	1	1000	850	95	17	20.5	1458	-	-	141	47	78
HPB-03-0650-NY	3	750	650	95	22	30.5	1713	115.3	-	201	67	173
HPB-03-0850-NY	3	970	850	95	22	30.5	1913	115.3	-	201	67	196
HPB-05-0650-NY	5	750	650	95	22	30.5	1713	115.3	115.3	201	67	223
HPB-05-0850-NY	5	970	850	95	22	30.5	1913	115.3	115.3	201	67	252

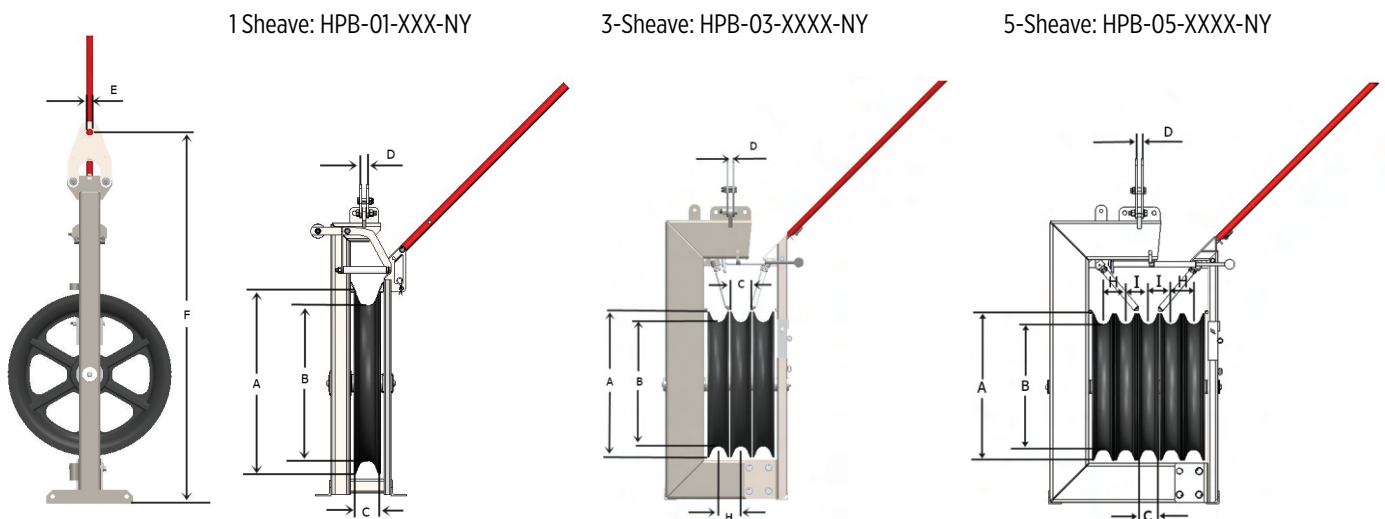

Pulley Blocks for Helicopter Stringing – Aluminum Sheaves

- Aluminum sheave molded in one piece for increased stability
- For single conductor, 2-, 3-, or 4-bundle
- Hinge mechanism, ball bearing mounted, for automatic insertion of the rope
- Galvanized steel frame with clevis attachment rotatable by 90°
- Bolted groove liners for easy exchange
- Maintenance-free ball bearings with high safe working load

Optional

- Groove liners of polyamide or aluminum
- Alternative distance between sheaves (H)
- Fixed clevis
- Grounding device with conductor rollers (used on polyamide groove liners)
- Grounding device with laterally mounted disk with carbon brush used on aluminum groove liners
- Special designs and breaking load on request

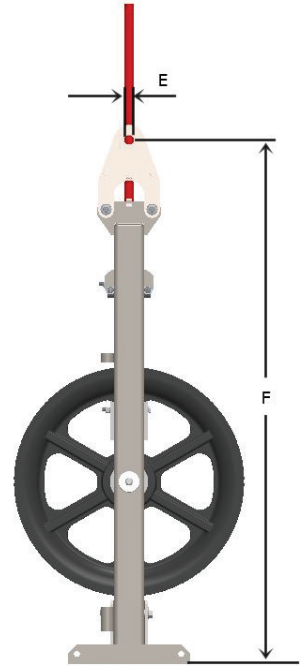

Part No.	Number of wheels	A (mm)	B (mm)	C (mm)	D (mm)	E (mm)	F (mm)	H (mm)	I (mm)	Breaking load (kN)	Working load (kN)	Weight (kg)
HPB-01-0650-AL	1	750	650	95	17	20.5	1258	-	-	141	47	77
HPB-01-0800-AL	1	900	800	95	17	20.5	1458	-	-	141	47	87
HPB-03-0650-AL	3	750	650	95	22	30.5	1713	115.3	-	201	67	197
HPB-03-0800-AL	3	900	800	95	22	30.5	1713	115.3	-	201	67	224
HPB-05-0650-AL	5	750	650	95	22	30.5	1713	115.3	115.3	201	67	263
HPB-05-0800-AL	5	900	800	95	22	30.5	1913	115.3	115.3	201	67	297

1 Sheave: HPB-01-XXX-AL

3-Sheave: HPB-03-XXXX-AL

5-Sheave: HPB-05-XXXX-AL

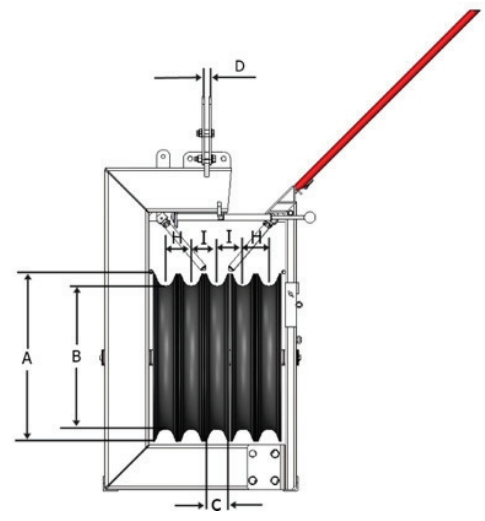
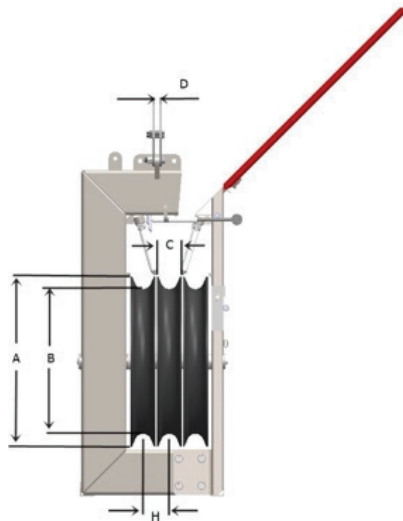
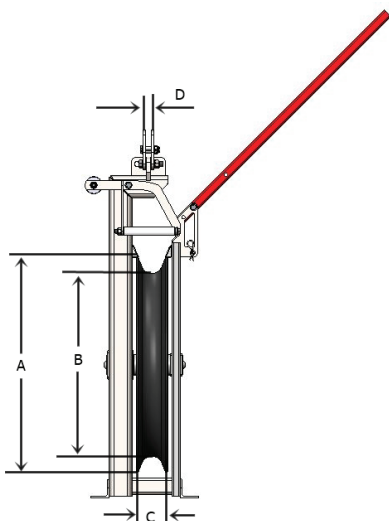

TANDEM Pulley Blocks (Helicopter) for Nylatron and aluminum sheave blocks



Tandem Pulley Block
Single Sheave
TDB-01-XXX-NY

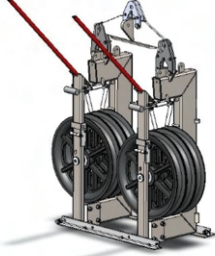

Tandem Pulley Block
3-Sheave
TDB-03-XXX-NY

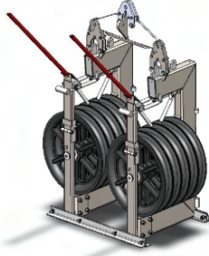

Tandem Pulley Block
5-Sheave
TDB-05-XXX-NY

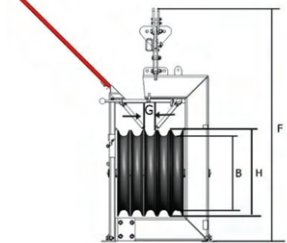
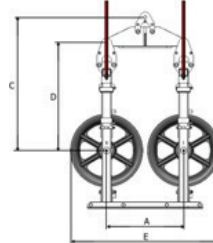

Part No.	Number of wheels	A (mm)	B (mm)	C (mm)	D (mm)	E (mm)	F (mm)	G (mm)	H (mm)	Breaking load (kN)	Working load (kN)	Weight (kg)
TDB-01-0650-NY	2	800	650	1382	1116	1552	1575	95	750	141	47	198
TDB-01-0850-NY	2	1000	800	1582	1316	1752	2092	95	900	141	47	216
TDB-03-0650-NY	6	800	650	1382	1116	1552	2030	95	750	201	67	406
TDB-03-0850-NY	6	1000	800	1582	1316	1752	2230	95	900	201	67	452
TDB-05-0650-NY	10	800	650	1382	1116	1552	2030	95	750	201	67	506
TDB-05-0850-NY	10	1000	800	1582	1316	1752	2230	95	900	201	67	564



With pressure roller for aluminum and polyamide groove liner OPTIONAL: with carbon brushes

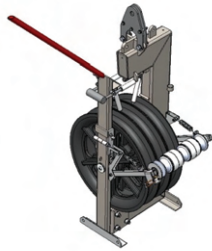

With laterally mounted disk and carbon brush



Grounding Cable with clamp

Optional Equipment

Part No.	Description	Specs
HPB-00-01	Grounding device for high induced currents: Single Sheave	Current induction 3.5 kA / 0.4s
HPB-00-03	3-Sheave	Conductor rollers for Nylatron sheaves or polyamide groove liners
HPB-00-05	5-Sheave	Laterally mounted disk and carbon brush for aluminium groove liners
Optional Items		
	Aluminum conductor clamp	clamping from 5-60 mm \varnothing 50 mm ² , length 10 mm
	Copper grounding cable with transparent insulation	
	Steel grounding clamps	for round conductors and frames up to 33 mm
Please specify version and optional items when ordering		

Array Block

Our helicopter frame array blocks are engineered for smooth pivoting, ensuring optimal alignment, precise tension control, and reduced wear on conductors. The high center of gravity allows the block to be very responsive and easy to manipulate when positioning it at various angles, allowing for finer control and easier handling.

Compatible with headboards, swivels, ropes, cover joints, and other standard and helicopter pulley equipment.

Available in three sizes to suit various conductor configurations, our array blocks are the ideal solution for applications requiring a large bending radius with ease of use and efficient handling.

Features:

- Frame: Steel – optional finish hot-dip galvanized or painted
- Wheels: Different configurations to choose from:
 1. Cast iron sheaves for center wheels, Nylatron sheaves for side wheels
 2. All cast iron sheaves
 3. All Nylatron sheaves
 4. All aluminum sheaves
- Integrated earthing device

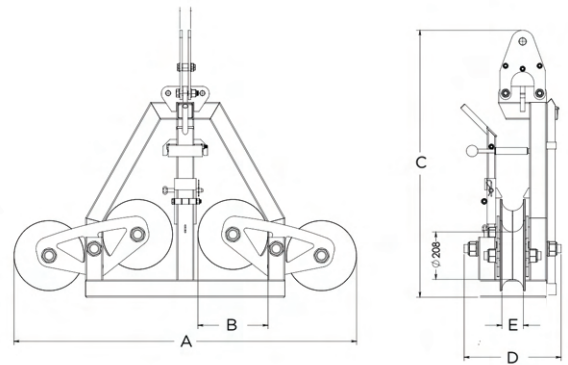

ARB-01-0095

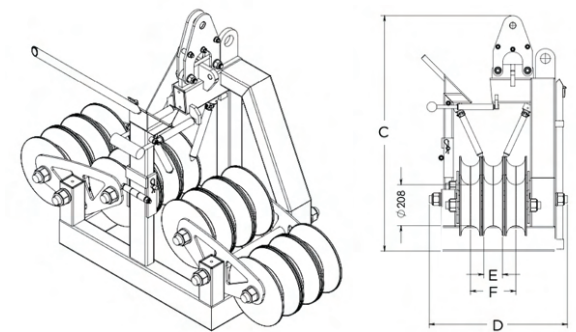

ARB-03-0095

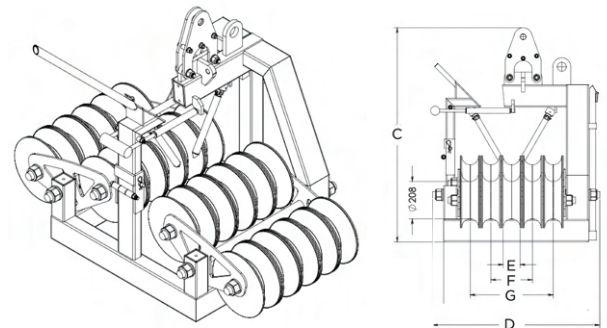

ARB-05-0095

Article No.	Number of wheels	A (mm)	B (mm)	C (mm)	D (mm)	E (mm)	F (mm)	G (mm)	Breaking load (kN)	Working load (kN)	Weight (kg)
ARB-01-0095	1x4	1505	308	1172	426	95	-	-	141	47	142
ARB-03-0095	3x4	1505	308	1192	700	95	230	-	201	67	307
ARB-05-0095	5x4	1505	308	1192	930	95	231	462	201	67	380

Hold-Down Block

The hold-down block is designed to keep ropes securely aligned on the ground during the tension stringing process. Constructed with a steel frame and high-strength nylatron sheaves, these blocks ensure stability and precision, preventing ropes from shifting or tangling.

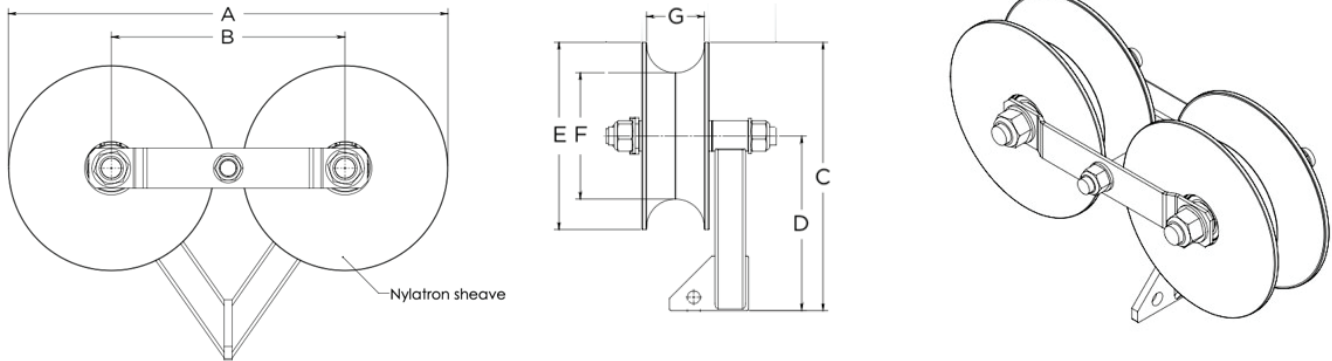

Part No.	A (mm)	B (mm)	C (mm)	D (mm)	E (mm)	F (mm)	G (mm)	Breaking load (kN)	Working load (kN)	Weight (kg)
HDB-01-0095	658	350	441	287	308	208	95	141	47	21

Pulley Block Storage System

Our versatile Pulley Block Storage System doubles as a transport box and a stackable storage shelf. It is custom-made for a wide range of block designs and sizes and available in two finishes: hot-dip galvanized and painted.

Part No.	Specs
SPB-01-00	Sizes and designs are created upon customer specification. One unit can usually fit 5-7 single blocks, 3-5 triple blocks or 2-3 five-sheave blocks.

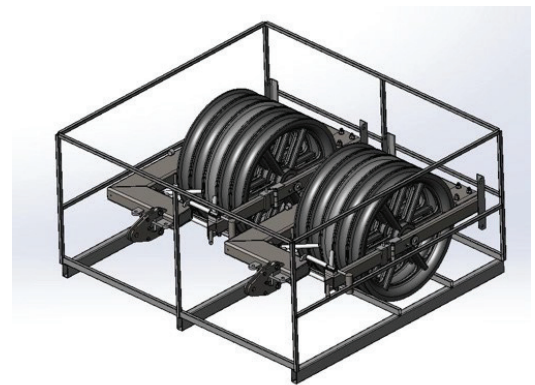

Single unit with Tandem Pulley Block TDB-05-0850



Safe and economic pulley block storage solution

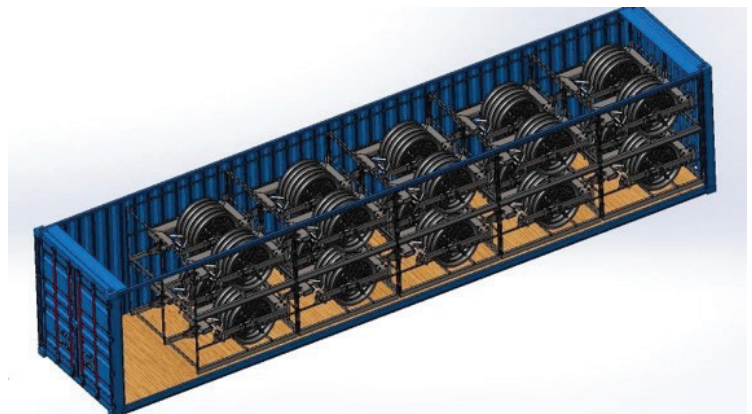

Optimum utilization of container space

Joint Protectors

When conductor midspan joints are compressed during the process of pulling conductors over the towers they need to be covered with an enclosure which prevents them from bending while travelling through the Pulley Blocks.

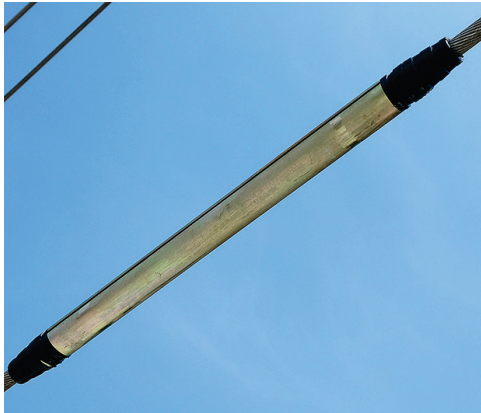

Designed to protect mid-span joints while being pulled over Pulley-Blocks during stringing

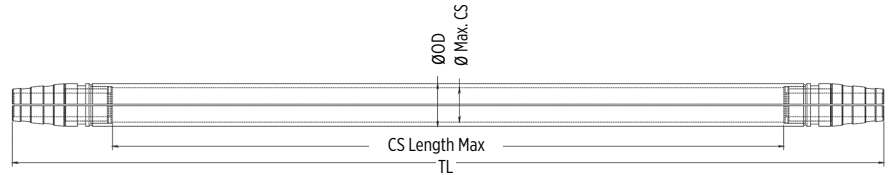

Please specify on the order:

- Mid-span joint
- Conductor diameter
- Max. compression sleeve OD
- Length after compression

Part No.	OD (mm)	Min. pulley groove width (mm)	Max. CS Ø	CS length after compression max (mm)	TL* (mm)	BL (kN)	Weight (Kg)
JOP-01-001	60.30	68	49	698	1038	2-5	6.75
JOP-01-002	73	80	58	829	1169	max 6.5	11.05

OD - outside diameter **CS** - compression sleeve **O.D. CS** - outside diameter of compression sleeve
TL - total length including rubber insert

* total length of joint protectors can be made up to order.

OPGW Counterweight

This device has the function to prevent rotation of OPGW during the stringing process. The new and very flexible design prevents problems when pulling over angled towers. We recommend using two counterweights to avoid rotation while one is on a pulley block. Delivery includes clamp unit and counterweight (approx. length 3 m), to avoid twisting

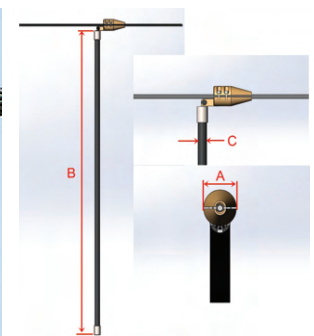
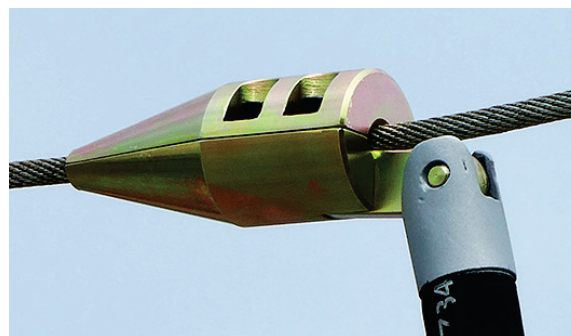

Part No.	No of counterweights	A (mm)	B (mm)	C (mm)	OPGW	Weight (Kg)
OCW-01-01	1	60	2930	38	10-17	5
OCW-01-02	1	60	3060	38	17-23	5

Customization options available upon request.

Please specify when ordering:

- Rope Ø
- Groove Ø of pulley block

Hydraulic Compression Tools

Our hydraulic compression units manufactured by our long year partner Sanwa Tekki Corporation are particularly light, efficient and convenient to use. We supply the hydraulic hose connections with “flat-face” hydraulic couplers, preventing the intrusion of dirt into the hydraulic system. They are equipped with double acting hydraulic cylinders with very fast compression cycle and highest reliability.



Compression Head HCH-01-0200

Part No.	Compression Force (ton)	Operating pressure (bar)	Max exterior Ø of compression (mm)	Max stroke (mm)	Weight (Kg)
HCH-01-0100	100	700	76	24	33
HCH-01-0200	200	700	90	33	98



Power Unit HPU-02-0700

Compression Head HCH-01-0100

Hydraulic Power Unit

A strong and reliable power unit with integrated valve control. Like the hydraulic compression head, it is equipped with “flat face” quick-action coupling for prevention of dirt intrusion.

In addition to the trusted HPU-02-0700, manufactured by Sanwa Tekki Corporation, Zeck now offers the new in-house development HPU-01-0700, which offers maximum reliability through three independent hydraulic filter systems.

Part No.	Engine	Dimensions LxWxH (mm)	Weight (Kg)
HPU-01-0700	Gasoline 4.3 KW	720x490x490	52
HPU-02-0700	Gasoline 4.3 KW	590x430x450	63

Die Sets for Hydraulic Compression Units

Part No.	Comment	Compression Force (ton)
HCD-01-0100	Die set for steel compression	100
HCD-02-0100	Die set for aluminium compression	100
HCD-01-0200	Die set for steel compression	200
HCD-02-0200	Die set for aluminium compression	200



Hydraulic Hose Kit

Our hydraulic hose kits include 2 maximum pressure hoses with flat face quick-action couplings. Designed to connect the compression head to the hydraulic power unit or a ZECK machine with an integrated hydraulic system for presses. The hydraulic hose kits are supplied without transport box (optional equipment).

Part No.	Length (meter)	Weight (Kg)
HHK-01-03	3	3.4
HHK-01-05	5	4.5
HHK-01-06	6	5.0
HHK-01-10	10	7.9
HHK-01-15	15	10.8
HHK-01-20	20	14.3
HHK-01-25	25	-



Optional Equipment

Part No.	ZECK GmbH part No.
HPU-00-01	Metal Box for power unit and hose kit
HCH-00-01	Metal box for press head and dies

Suspension Ladders

These ladders are designed to be used in hanging position at the tower-cross arms for performing works, for instance at the insulator chains. They can be used also as anchoring ladders if supplied with the optional foldable conductor hook or tower- and conductor hook (SLA-00-02 or SLA-00-03). If supplied with the optional available anti-fall system (SLA-00-01) the ladder is supplied with a guide rail on the left side.

The tower hook is made of galvanized steel and equipped with a safety chain to prevent accidental fall down of the ladder. The ladder itself is a welded structure of first grade extruded aluminum pipes. The rungs are corrugated for slip protection. The working load in hanging position is 3 kN. If used as anchoring ladder (with optional SLA-00-02 or SLA-00-03) the maximum allowable working load is 1 kN.

Different dimensions are available upon request.

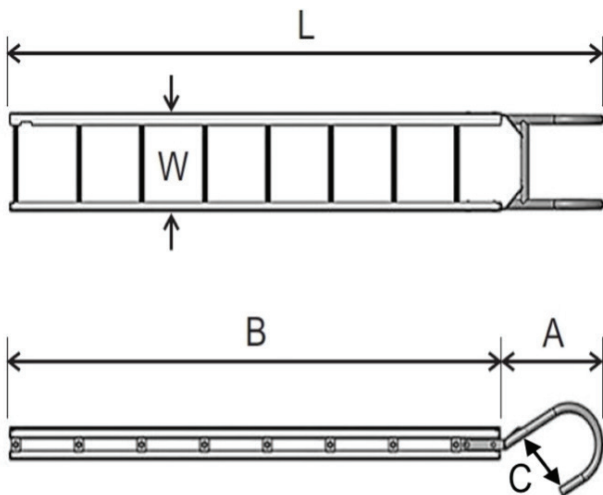

We test our suspension ladders in compliance with specific testing guidelines developed by TÜV, Germany.

Part No.	W (mm)	Sections qty.	SWL vertical (kN)	SWL horizontal (kN)	L=A+B (m)	Hook length C (mm)	Weight (Kg)
SLA-01-0250	305	1	3	1	2.5	220	16
SLA-01-0300	305	1	3	1	3	220	18
SLA-01-0400	305	1	3	1	4	220	20
SLA-01-0500	305	1	3	1	5	220	24
SLA-01-0600	305	1	3	1	6	220	28
SLA-02-0600	305	2	3	1	6 m (4+2)	220	30
SLA-02-0800	305	2	3	1	8 m (4+4)	220	38
SLA-02-1000	305	2	3	n.a.	10 m (5+5)	220	46
SLA-03-1200	305	3	3	n.a.	12 m (4+4+4)	220	55
SLA-03-1600	305	3	3	n.a.	16 m (6+4+6)	220	70

other lengths and designs available upon request

Suspension Ladders

Fall arrester not included but available on request in different designs



anti-fall system SLA-00-01

SLA-00-03

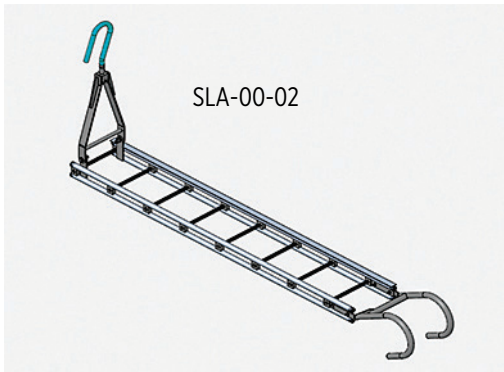

SLA-00-02



SLA-00-04

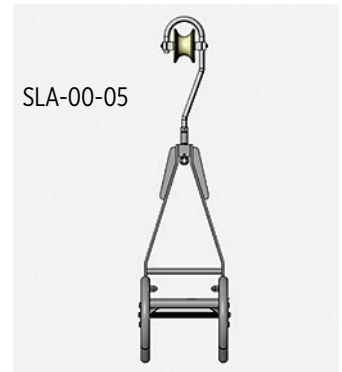

SLA-00-05

Optional equipment for Suspension Ladders

Part No.	Description	Weight (Kg)
SLA-00-01	anti-fall system (glider/arrester and T-profile on left ladder stringer)	1
SLA-00-02	foldable and turnable conductor hook	4
SLA-00-03	foldable and turnable tower hook	9
SLA-00-04	hook with polyamide sheave	5
SLA-00-05	hook with aluminium sheave	6

Anchoring Ladders (2kN SWL)

Anchoring Ladders are used as Working Platforms along the insulator chains of Tensions Towers. If required they can be also used vertically as Suspension Ladders.

Optionally we can equip these Anchoring Ladders with a foldable tower hook and different sheaves/pulleys on the conductor hook for easier movement. Different lengths and sections are available upon request. The Anchoring Ladders with 2 kN horizontal workload are designed with tri-angular structure.

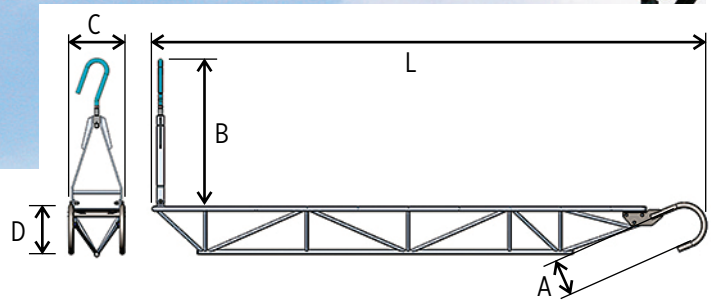
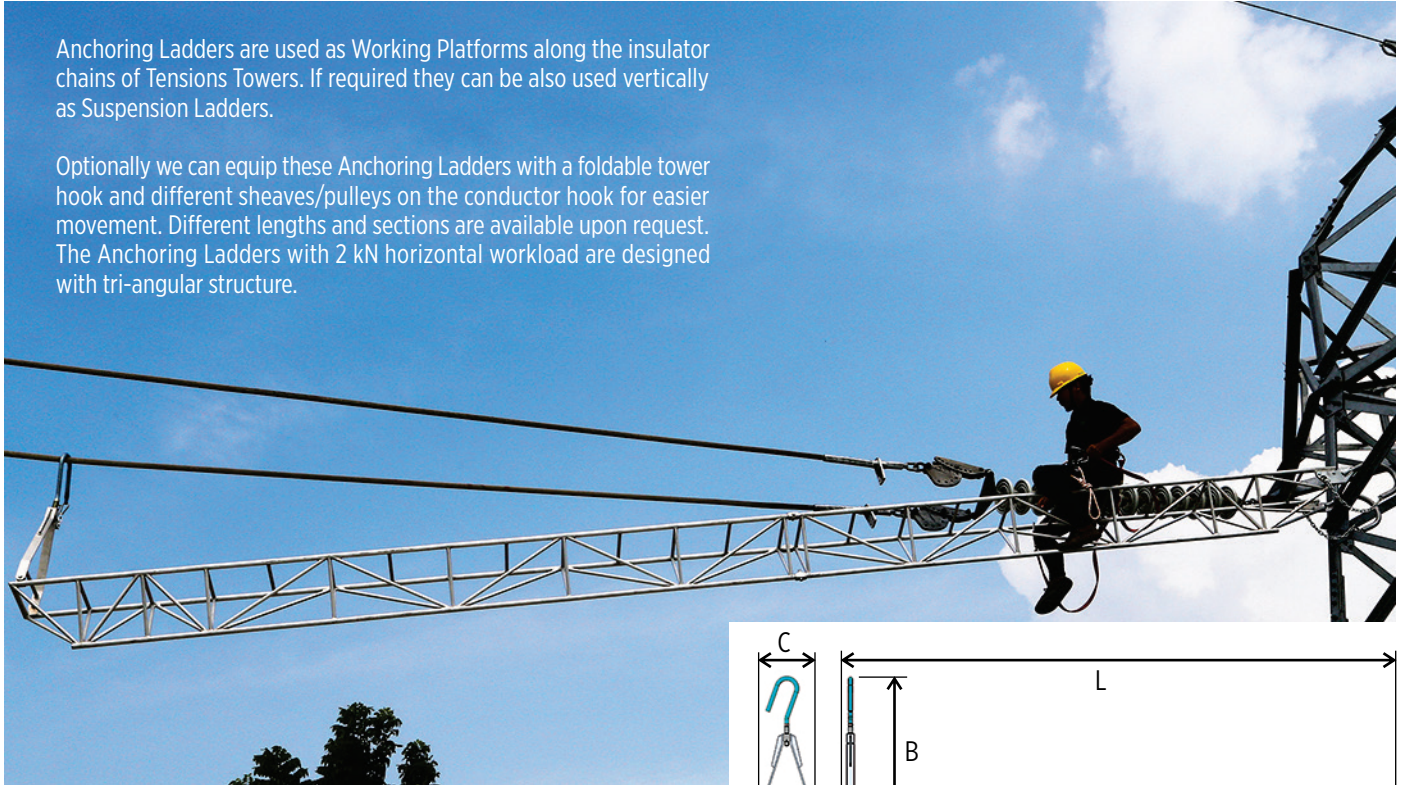

Part No.	L m	Sections qty.	SWL horizontal (kN)	SWL vertical (kN)	A (mm)	B (mm)	C (mm)	D (mm)	Weight (Kg)
ALS-01-0350	3.5	1	2	3	220	900	320	320	25
ALS-01-0400	4.0	1	2	3	220	900	320	320	27
ALS-01-0500	5.0	1	2	3	220	900	320	320	31
ALS-01-0600	6.0	1	2	3	220	900	320	350	35
ALS-02-0600	6 (4+2)	2	2	3	220	900	320	350	36
ALS-02-0700	7 (4+3)	2	2	3	220	900	320	350	40
ALS-02-0800	8 (4+4)	2	2	3	220	900	320	350	44

Optional Equipment:

Part No.	Description	Weight (Kg)
ALS-00-01	foldable and turnable tower hook	9
ALS-00-02	foldable and turnable conductor hook with polyamide sheave	5
ALS-00-03	foldable and turnable conductor hook with aluminium sheave	6
ALS-00-04	anti-slip aluminium plate	7

other lengths available upon request
anti-slip aluminium plate is weight per 2 meters length

Anchoring Ladders (3kN SWL)

Anchoring Ladders are used as working platforms along the insulator chains of Tension Towers. If required they can be also used vertically as suspension ladders.

Optionally we can equip these Anchoring Ladders with a foldable tower hook and different sheaves/pulleys in the conductor hook for easier movement. Different lengths and sections are available upon request.

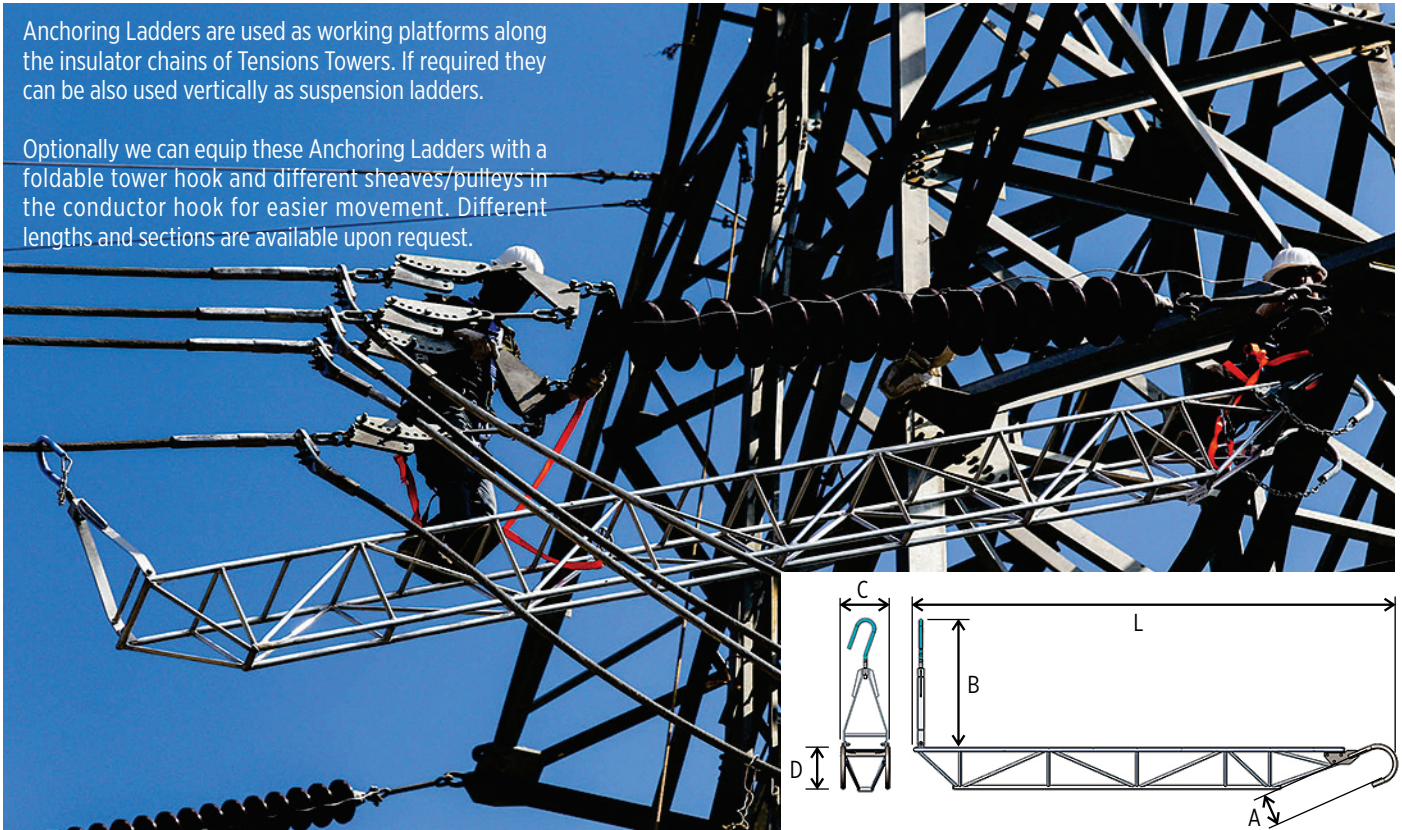

Part No.	L m	Sections qty.	SWL horizontal (kN)	SWL vertical (kN)	A (mm)	B (mm)	C (mm)	D (mm)	Weight (Kg)
ALT-01-0350	3.5	1	3	3	220	900	320	320	26
ALT-01-0400	4.0	1	3	3	220	900	320	320	29
ALT-01-0500	5.0	1	3	3	220	900	320	350	34
ALT-01-0600	6.0	1	3	3	220	900	320	350	39
ALT-02-0600	6 (4+2)	2	3	3	220	900	320	350	40
ALT-02-0700	7 (4+3)	2	3	3	220	900	320	350	45
ALT-02-0800	8 (4+4)	2	3	3	220	900	320	350	50
ALT-02-1000	10 (5+5)	2	3	3	220	900	320	350	60
ALT-03-1200	12 (4+4+4)	3	3	3	220	900	320	350	72
ALT-03-1800	18 (6+6+6)	3	3	3	220	900	350	446	115
ALT-04-2000	20 (5+5+5+5)	4	3	3	220	900	350	446	157

Optional Equipment:

Part No.	Description	Weight (Kg)
ALS-00-01	foldable and turnable tower hook	9
ALS-00-02	foldable and turnable conductor hook with polyamide sheave	5
ALS-00-03	foldable and turnable conductor hook with aluminium sheave	6
ALS-00-04	anti-slip aluminium plate	7

other length available upon request
anti-slip aluminium plate is weight per 2 meters length

Working Platforms for jumper construction

These platforms provide linesmen a safe working area at Tension Towers, particularly for the construction of conductor jumpers between insulator chains. They consist of a tubular structure of welded aluminium pipes. In the centre they are equipped with a suspension device and at both ends with anchoring points.

We particularly recommend to equip the platforms with the optionally available sheet metal stepping ground, which increases safety of the linesmen significantly. Optionally available is furthermore a second Anti-Fall Barrier.

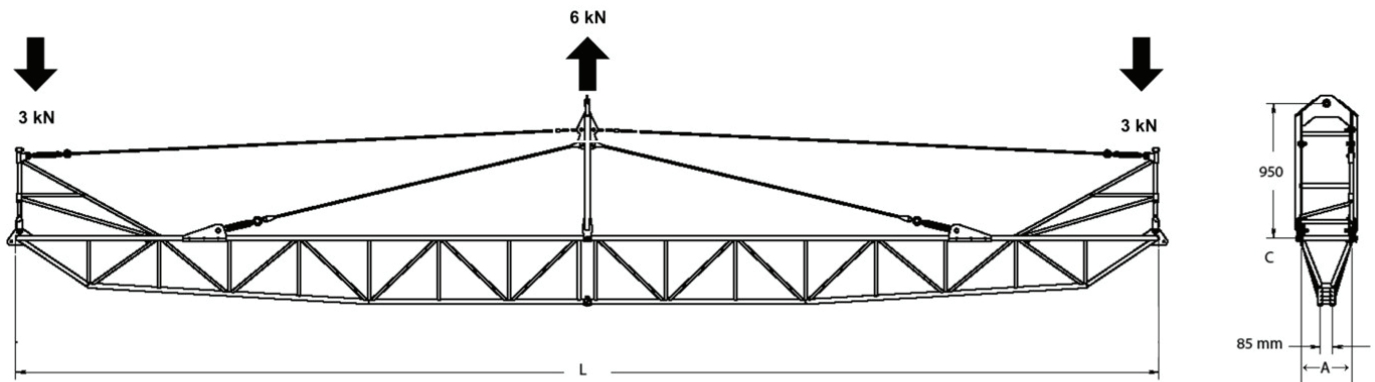

Part No.	Working platform length L and sections m	A (mm)	C (mm)	Weight (Kg)
PLA-01-0700	7	350	446	80
PLA-01-0800	8	350	446	88
PLA-01-1000	10	350	446	105
PLA-01-1200	12	350	446	116
PLA-01-1400	14	350	446	129
PLA-01-1600	16	350	446	144
PLA-01-1800	18	350	446	164
PLA-01-2000	20	450	550	200
PLA-01-2400	24	450	550	250
PLA-01-2600	26	450	550	265
PLA-01-3000	30	450	550	470
PLA-01-3400	34	450	550	515

other lengths and designs available upon request

Working Platforms

Optional Equipment

Part No.	Description
PLA-00-01	second anti-fall barrier
PLA-00-02	press trolley, 360 degree turnable
PLA-00-03	railway profile for press trolley
PLA-00-04	non-skid aluminium perforated plate for anchoring ladder and working platform (mechanical stamping)



Press trolley (PLA-00-02)



Railway profile (PLA-00-03)



Non-skid aluminium perforated plate for anchoring ladder and working platform (PLA-00-04)

Sagging Thermometer

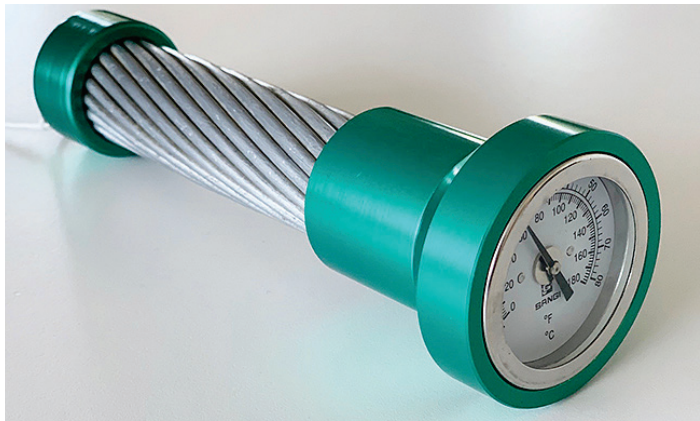

This thermometer is for measuring the conductor temperature during sagging process. The measuring range is from -20 to 80 degree Celsius, it is delivered with calibration certificate and transport case.

Part No.	Weight (Kg)
STN-01-01	0.6

Sag Scope

During the sagging process this device allows accurate monitoring of the conductor sag. It is equipped with a fine adjustment on all axles comes with tower mounting fixture and transport case.

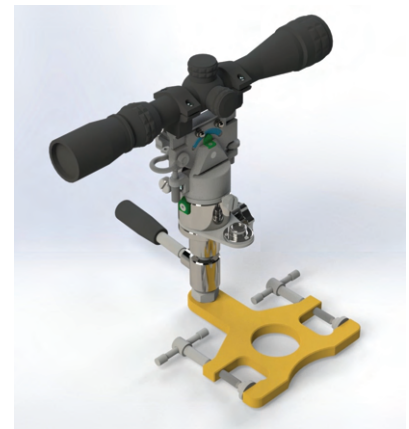

Part No.	Magnification & Objective Lens	Length (cm)	Weight scope only (g)
SCO-01-01	3-9x40	31	340

Spacer Key

A smart tool for the installation of spacers on the rope. Used like a customized set of pliers, the design ensures precise and secure spacer installation, significantly reducing downtime and enhancing overall workflow efficiency. Strong, lightweight, and easy to use. Made of aircraft-grade aluminum with anodized grip.

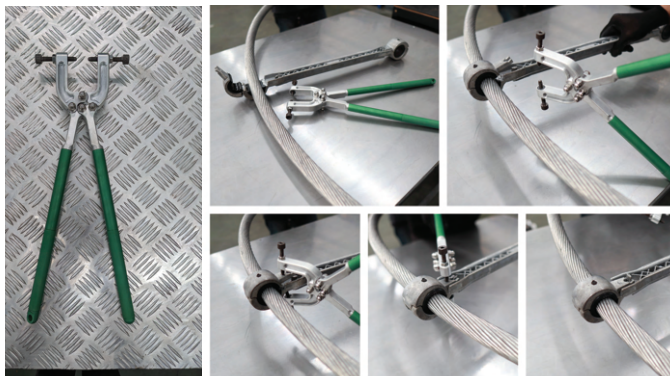

Part No.	Max. mouth opening (mm)	Clamping range (mm)	Weight (Kg)
SCK-01-01	85	0-40	1.05

Line Cars - Overview

Our precision-engineered line cars provide a lightweight and convenient means for operators to travel along the conductor lines between towers. These inspection trolleys allow linemen to traverse the conductors safely to perform their tasks (e.g. spacer installation, inspections, installation of aircraft warning balls) high above ground. More details on the various models can be found on the following pages.

Part No.	Operators	Conductors	Motorized	Page
LSE-01-01	1	1	No	33
LCA-01-01	1	1	Yes / Petrol	34
LCP-03-02/03/04	2	2/3/4	No	35
LCE-01-02/03/04	1	2/3/4	Yes / Electric	36
LCA-02-02/03/04	2	2/3/4	Yes / Petrol	37
LCP-01-02/03/04	1	2/3/4	No	38
LCP-02-02/03/04	2	2/3/4	No	38
LCP-01-01	1	1	No	39
LCP-02-01	1	1	No	39

Line Seat (for single conductor/earth wire)

Part No.	Description	SWL (Kg)	Dimension LxWxH (mm)	Weight (Kg)
LSE-01-01	Line Seat for single conductor/earthwire	100	960x795x1120	19

The Line Seat can be easily moved over single conductor or earth wires, for instance for installation of aircraft warning balls, vibration dampers. It is equipped with two combined stationery and dynamic brakes.

Please note: When riding over single conductors/ earth wires a safety line with sufficient breaking load needs to be installed.



Line Car with Drive Unit (gasoline) - “New Generation” - One operator / Single conductor / Tower surpassing ability

Our newly developed Line Car LCA-01-01 is a Zeck TSE exclusive, capable to surpass over suspension towers through four openable wheel arms. It is powered by a 6.3 KW Honda gasoline engine which drives a hydraulic pump and motor on two axles.

Without being pulled by external force it can travel along conductor spans and climb slopes up to 25% inclination with a maximum speed of 40 m/min.

The hydraulic system serves as a very effective dynamic brake. Like all our line cars, the LCA-01-01 is also equipped with a mechanical parking brake and a distance counter.



Part No.	Description	Safe Working Load (kg)	Conductor Dia. Range (mm)	Dimensions LxWxH (mm)	Weight (kg)
LCA-01-01	Single conductor	150	6-50	1605x840x2080	150

Optional Equipment:

Part No.	Description	Safe Working Load (kg)	Weight (kg)
LCP-00-02	Lifting Device	500 kg	9 kg
LCP-00-03	Fire Extinguisher	-	2 kg

Line Car - “New Generation”

- One operator / 2-4 conductors / Tower surpassing ability

Our “New Generation” Line Cars are equipped with four wheels, mounted with independent suspension systems instead of rigid axles. The Line Cars are easier to mount on the conductors and capable to surpass suspension towers with a T-bar. Thanks to the innovative mechanism with only four wheels, they surpass suspension towers in less time.

Standard Features

- Rubber wheels
- Lightweight aluminum frame
- Four lifting points
- Distance Counter



Part No.	Description	Safe Working Load (kg)	Spacing between conductors (mm)	Dimensions LxWxH (mm)	Weight (kg)
LCP-03-02	2-bundles	150 kg	400, 450, 500, 520	1900x820x1570	123
LCP-03-03	3-bundles	150 kg	400, 450, 500, 520	1900x820x1570	129
LCP-03-04	4-bundles	150 kg	400, 450, 500, 520	1900x820x1570	134

Optional Equipment:

Part No.	Description	Safe lifting load (Kg)	Weight (Kg)
LCP-00-02	Lifting Device	500	9
LCP-00-04	Catch Net for fall prevention		



Lifting Device (LCP-00-02)

Line Car with Drive Unit (electric-driven)- “New Generation” - One operator / 2-4 conductors / Tower surpassing ability

The new Line Car LCE-01-xx is equipped with a power unit featuring four electric motors, collectively providing 1000W of power. Supported by two 24V DC batteries with a combined capacity of 150 Ah, the system enables the cart to operate continuously for up to three hours on a single charge. Without being pulled by external force it is capable to travel along conductor spans and climb slopes up to 20 % inclination. The maximum travelling speed is 43 m/min. The electric system serves also as a very effective dynamic brake. Like all our line cars, the LCE-01-xx is additionally equipped with a parking brake.

With four wheels mounted on independent suspensions, the line car can easily and safely pass over suspension towers without the need to be lifted up and down at each tower.

Standard Features

- Rubber wheels
- Lightweight aluminum frame
- Four lifting points
- Distance Counter



Part No.	Description	Safe Working Load (kg)	Spacing between conductors (mm)	Dimensions LxWxH (mm)	Weight (kg)
LCE-01-02	2-bundles	150 kg	400, 450, 500, 520	1900x820x1570	249
LCE-01-03	3-bundles	150 kg	400, 450, 500, 520	1900x820x1570	255
LCE-01-04	4-bundles	150 kg	400, 450, 500, 520	1900x820x1570	260

Optional Equipment:

Part No.	Description	Safe Working Load (kg)	Weight (kg)
LCP-00-02	Lifting Device	500 kg	9 kg
LCP-00-03	Fire Extinguisher	-	2 kg
LCP-00-04	Catch Net for fall prevention		

Line Car with Drive Unit (gasoline)

- Two operators / 2-4 conductors / Tower surpassing ability

The Line Cars LCA-02-xx are powered by a 6.3 KW Honda gasoline engine which drives a hydraulic pump and motors on two axles. Without being pulled by external force they are capable to travel along conductor spans and climb slopes up to 25 % inclination. The maximum travelling speed are 40 m/min. The hydraulic system serves also as a very effective dynamic brake. Like all our line cars, the LCA-02-xxx is equipped with a parking break.

With four openable axles and a jack for closing them, the LCA-02-xxx is capable to surpass over suspension towers.



Part No.	Description	Safe Working Load (kg)	Spacing between conductors (mm)	Dimensions LxWxH (mm)	Weight (kg)
LCA-02-02	2-bundles	250 kg	400-635	2716x1305x1800	215
LCA-02-03	3-bundles	250 kg	400-635	2716x1305x1800	220
LCA-02-04	4 bundles	250 kg	400-635	2716x1305x1800	225

Optional Equipment:

Part No.	Description	Safe Lifting Load (kg)	Weight (kg)
LCP-00-02	Lifting Device	500 kg	9 kg
LCP-00-03	Fire Extinguisher	-	2 kg

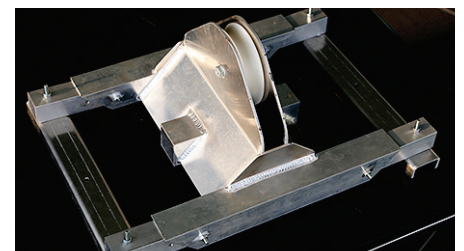

Lifting Device (LCP-00-02)

Line Car - *One operator / 2-4 conductors*

The LCP-01-xxx line cars are designed for single-operator use. They are equipped with a parking brake and a dynamic disk brake.

A meter counter is included as standard equipment.

Part No.	Description	SWL (Kg)	Spacing between conductors (mm)	Dimensions LxWxH (mm)	Weight (Kg)
LCP-01-02	2-bundles	150	400-510	1178x820x1410	62
LCP-01-03	3-bundles	150	400-510	1178x820x1410	65
LCP-01-04	4 bundles	150	400-510	1178x820x1410	66



Line Car

- *Two operators / 2-4 conductors / Tower surpassing ability*

Our models LCP-02 are designed for a safe working load of 250 KG. The four axles can be opened in sequence. This enables the Line Car to pass over suspension towers instead of lowering it down and lifting it up again at every tower.

The Line Car LCP-02 is welded of superior aluminium alloy and equipped with meter counter and parking brake. Within the scope of supply is also a dynamic brake system by two hydraulic activated disk brakes.

Upon ordering the distance between the conductors need to be specified.



Part No.	Description	SWL (Kg)	Spacing between conductors (mm)	Dimensions LxWxH (mm)	Weight (Kg)
LCP-02-02	2-bundles	250	400 - 510	2078x820x1270	90
LCP-02-03	3-bundles	250	400 - 510	2078x820x1270	96
LCP-02-04	4-bundles	250	400 - 510	2078x820x1270	100

Line Car - *One operator / Single conductor*

The Line Car is like the Line Seat used for traveling over single conductors or earth wires for installation of aircraft warning balls, vibration dampers, etc. The operator is positioned in a trolley. This model is equipped with stationary brake plus dynamic disk brake. A meter counter is included in the standard equipment.

Please note: When riding over single conductors/earth wires a safety line with sufficient breaking load needs to be installed.



Part No.	Description	SWL (Kg)	Dimension (mm)	Weight (Kg)
LCP-01-01	single conductor / earthwires	150	645x725x1956	43

Line Car - *Two operators / Single conductor*

Line car for 2 people, suitable to work on single conductor or earth wire. Welded from stable and high-strength aluminum. It is equipped with parking brake as well as dynamic disk brake with two parking brakes and large nylon wheels with a diameter of 440 mm. A meter counter is included in the standard equipment.



Part No.	Description	SWL (Kg)	Dimension LxWxH (mm)	Weight (Kg)
LCP-02-01	single conductor / earthwire	200	2500x750x2186	100

Line Bicycles



Line Bicycles allow linesman to safely travel along transmissionline conductors and earthwires. The advantage towards Line Cars is that they are muscle powered. Without any motorization the operator can pedal along the line for inspection, installation of spacers, vibration dampers or aircraft warning spheres. Models for single conductor, twin, triple, quad-bundled conductors are available

Characteristics:

- High-tensile ball-bearing mounted neoprene sheaves with fall protection
- Static braking device with jaws locking on conductors, controlled by lever
- Dynamic disc braking device at the drive shaft, controlled by lever
- Adjustment to conductor spacing between 400 and 510 mm
- Comfortable sitting position
- Fall protection
- Meter counter device

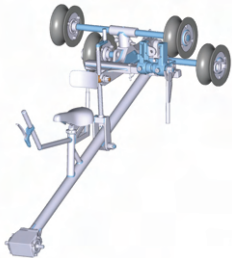
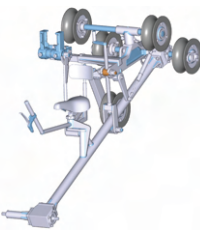
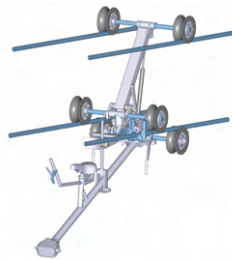
Part No.		Part No.	
	<p>LBP-01-01</p> <p>Description for single conductor / earthwire</p> <p>SWL (Kg) 100</p> <p>Dimensions LxWxH (mm) 1050x554x1655</p> <p>Weight (Kg) 25</p>		<p>LBP-01-02</p> <p>Description for 2-bundle conductors</p> <p>SWL (Kg) 100</p> <p>Dimensions LxWxH (mm) 650x770x1560</p> <p>Weight (Kg) 32</p>
	<p>LBP-01-03</p> <p>Description for 3-bundle conductors</p> <p>SWL (Kg) 100</p> <p>Dimensions LxWxH (mm) 706x643x1560</p> <p>Weight (Kg) 38</p>		<p>LBP-01-04</p> <p>Description for 4-bundle conductors</p> <p>SWL (Kg) 100</p> <p>Dimensions LxWxH (mm) 850x770x1903</p> <p>Weight (Kg) 42</p>

Railway Construction Equipment and Catenary

ZECK GmbH manufactures highly specialized machines for the railway construction industry:

- Working platforms and baskets
- Dumpers and trailers
- Catenary installation units (“wiring trains”) mounted on
 - Rail-bound vehicles
 - Railroad trucks

ZECK catenary installation units guarantee careful and precise installation of catenary. The machines can be designed according to individual client specifications. The units are mounted on railway vehicles or wagons employed in building urban and intercity railways, enabling compliance with local regulations.

Please contact us for further information about machines, technical details and services.
www.zeck-gmbh.com

Railroad Platforms and Baskets



RR C-POD 10



RR LAMA DN



RR LAMA DP HEV



RR D-POD 16

Dumpers and Trailers



RR D-SKIP 5



RR D-TRAY 6

Catenary Installation Units



Mounted on wagon



Pulled by railroad truck

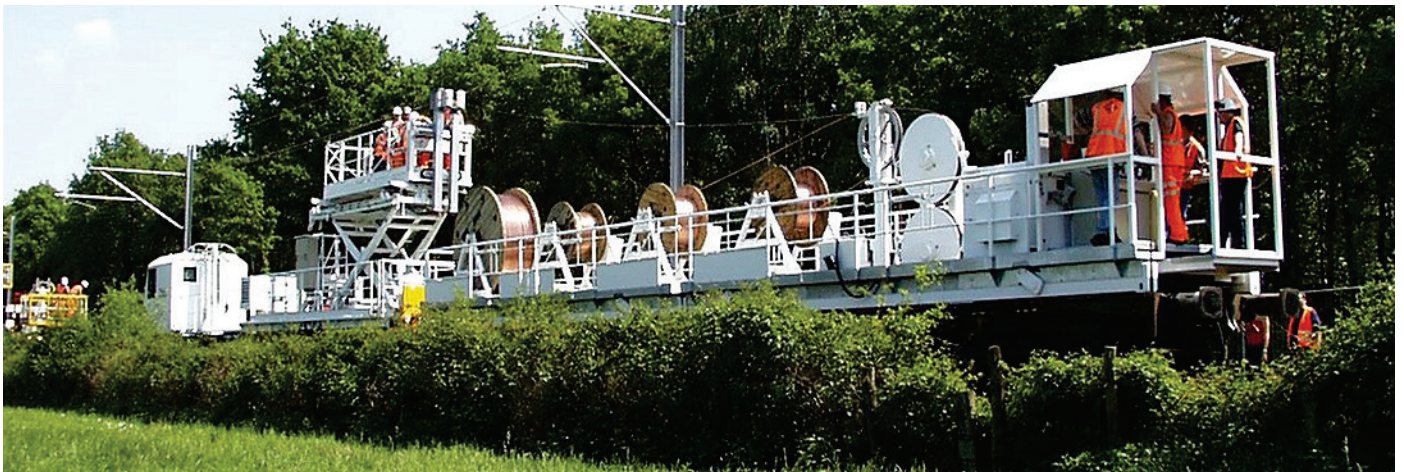

Mounted on self-propelled wagon

Underground Utility Construction

As an extension of our product line we are representing the following European companies in Sales & Aftersales Service, exclusively for the Thailand market.

CBS **PRODUCTS**

Leaders in Advanced Cable Installation Equipment

CBS Products Ltd., Oakham, United Kingdom

CBS Products is at the forefront of cabling technology, the design and manufacture of installation equipment for LV Distribution lines, Railway Tracksides and underground CATV / Telecommunication networks, including the handling of Fibre Optic Cables. They offer also offer a comprehensive range of standard equipment.

www.cbsproducts.com

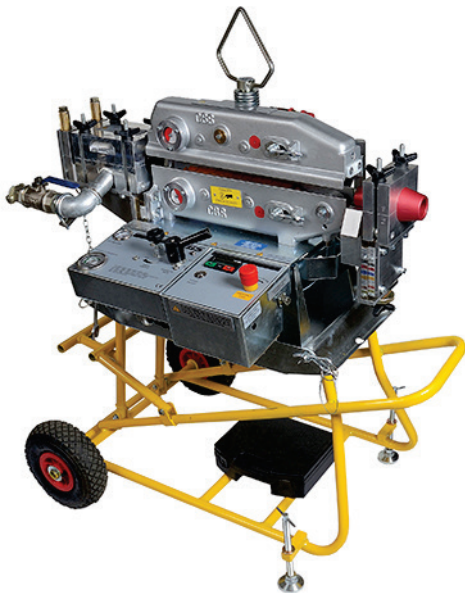

Cable blowing machine

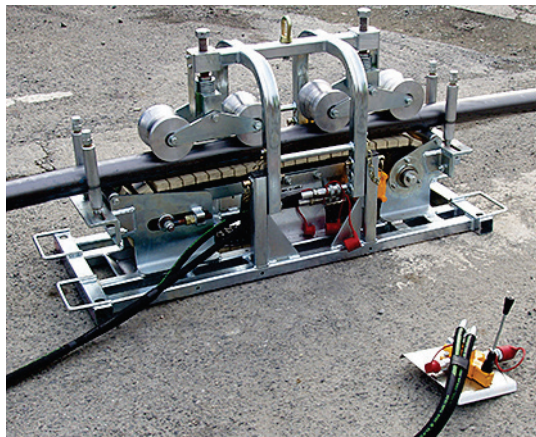

Cable pusher



Duct rods



Puller for distribution lines



Cables winch

Foeckersberger



Walter Fockerperger GmbH is a manufacturer of a unique pipe and cable laying plow system. The system works as follows:

A winch crawler equipped with a large anchor spade is positioned 110 meters ahead of the plow, firmly anchoring itself into the ground to ensure stability before commencing the pulling process. Once the plow is in motion, it efficiently installs cables or pipes at a rate of 100 meters in just 3 to 15 minutes, depending on various factors such as laying depth and ground conditions.

In optimal conditions, the system can achieve installation speeds of up to 1,500 meters per hour, making it a highly efficient solution for your projects. What's more, the cable laying plow is designed with adjustable wheels, enabling it to seamlessly adapt to undulating terrain, overcome slopes, ditches, and other obstacles with ease.

Benefits in one view

- Innovative system for trenchless pipe and cable laying
- The world market leader in the field of trenchless pipe and cable laying
- The world's strongest winch and laying-plough systems with up to 360 tonnes of tractive force
- Used on every continent and on any terrain
- Incredible performance: 10.000 metres per day and a maximum pipe diameter of 630 mm
- Ecological and sustainable - no trench, minimum impact on the natural environment

Contact us for more information to discover the unparalleled versatility and efficiency of this pipe and cable laying plow system from Walter Fockerperger GmbH.

www.foeck.com/en

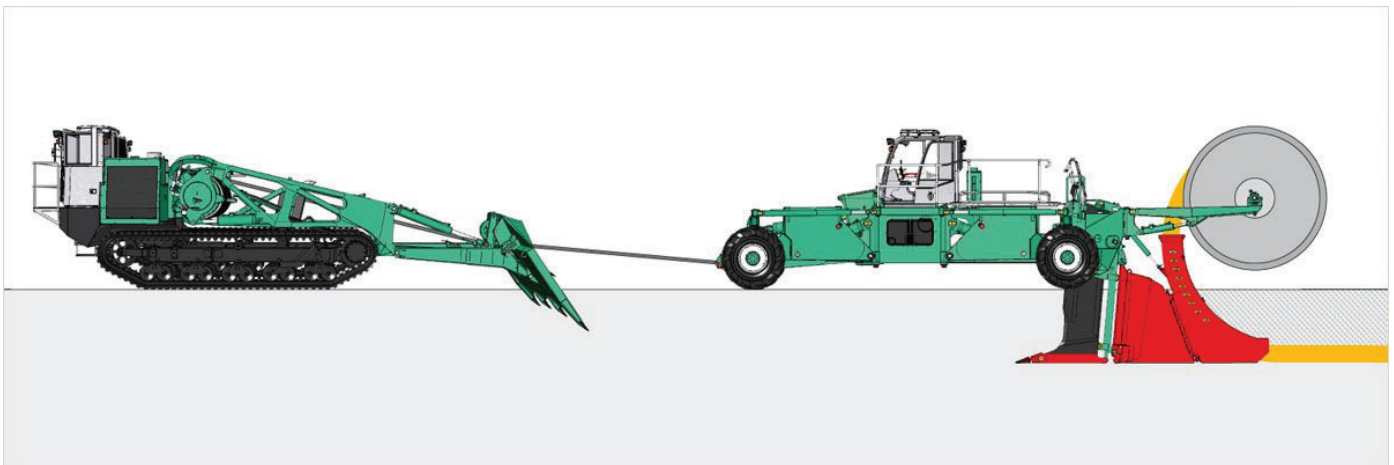

Foekersberger



Foek ploughing method for all terrains



Laying pipes through
watercourses



Laying system on
rocky ground



Laying system in mud
and bog areas



Laying steel pipes using
the torpedo plow method



Laying of power cable



Laying of gas- and
waterpipes

Address and Contact

Head Office & Factory

ZECK TSE International Limited

52, Mu 1, Samnak Bok Sub-district,
Mueang Chon Buri District,
Chon Buri Province 20000
Thailand

Tel.: +66 3 819 5768 - 9

E-Mail: info@zeck.co.th

Internet: www.zeck.co.th



SCAN ME



Bangkok Office

88/53 Ramkhamhaeng 174,
Minburi, Bangkok 10510
Thailand

Tel.: +66 2 540 0796

E-Mail: info@zeck.co.th



SCAN ME



For Sales Inquiries:

Ms. Naowadi "Nadi" Datthuyawat

Tel. +66 62 229 1645

E-Mail: nd@zeck.co.th

Mr. Dirk Braun-Friderici

Tel. +66 81 617 8407

E-Mail: dbf@zeck.co.th

Mr. Sumit Chauhan

Tel. +91 95600 44423

E-Mail: sumit@zeck.in